

Nacrti položaja kod svečane sv. mise.

C == celebrant

c == ceremonijar

D == đakon

t == turifer

S == subdakon

a₁, a₂ == svječnošće (akoliti)

Bilješka. Kamo je okrenut gornji dio slova, onamo gleda lice dotičnoga službenika.

1. Kad se pristupi k oltaru

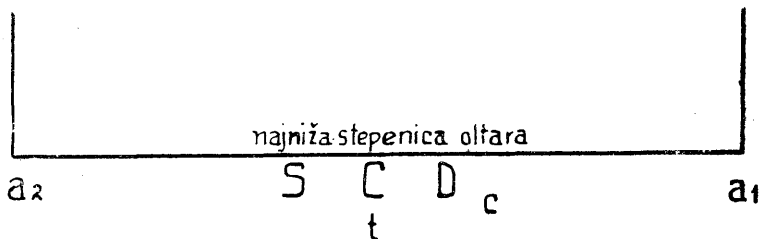

2. Confiteor

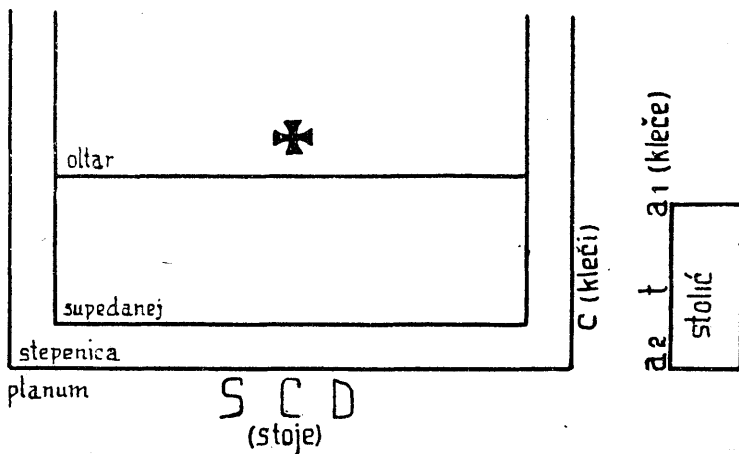

3. Stavljanje tamjana *

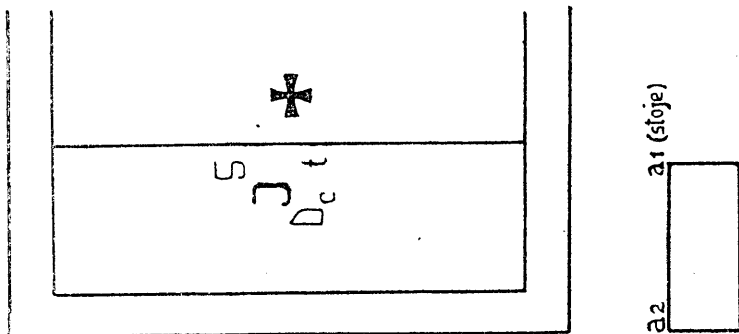

* Ovako stoje i kod stavljanja tamjana kod ofertora, samo što S stoji in
placu držeći patenu.

4. Kadenje oltara

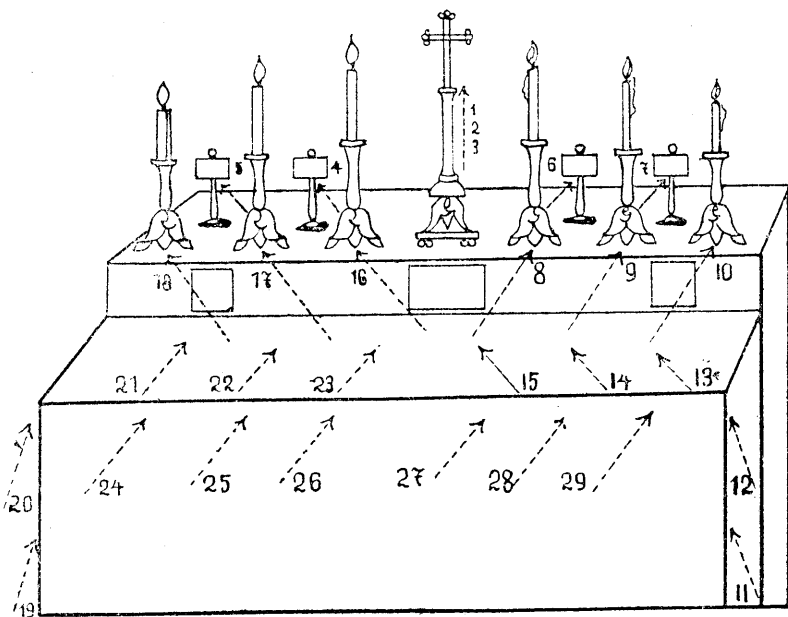

5. Kadenje celebranta

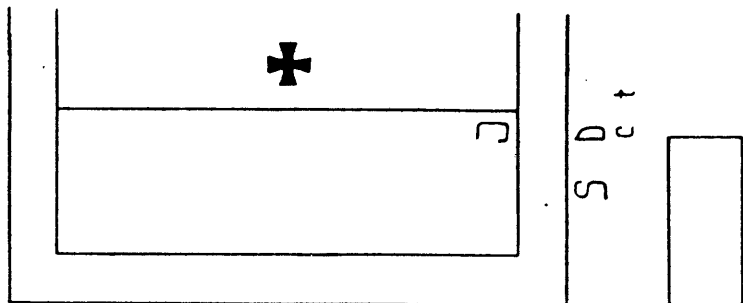

6. Introit

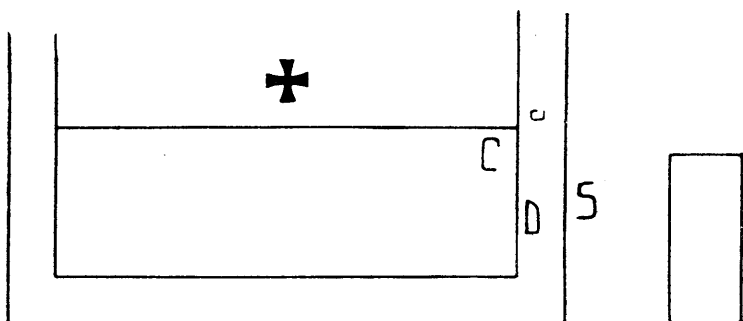

7. Gloria (i Credo)

a) Intonacija i moljenje

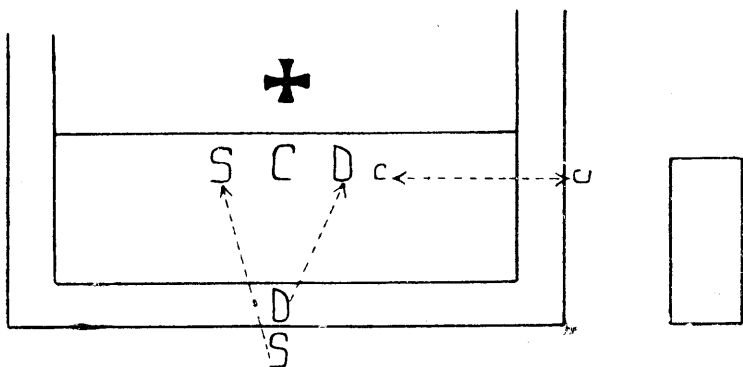

b) Polazak, k sjedalima, sjedenje
i povratak k oltaru

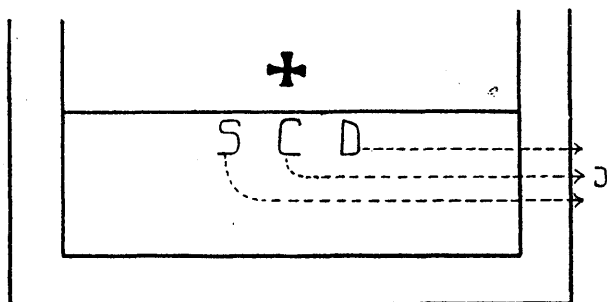

8. Dominus vobiscum, Oracija i
postcommunio

D J S
S C D

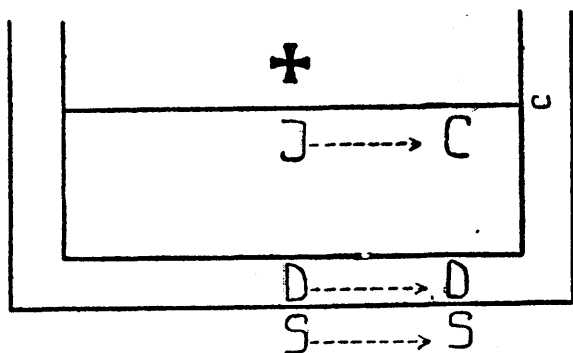

9. Čitanje epistole

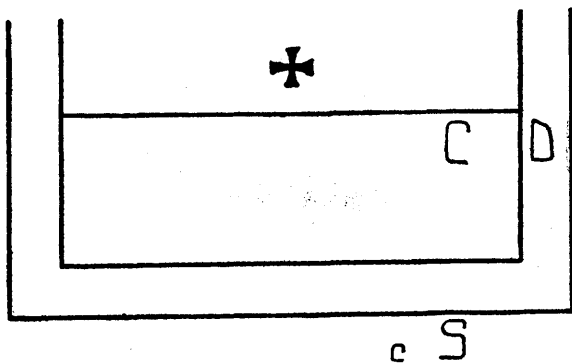

10. Subđakon ljubi ruku celebrantu poslije epistole

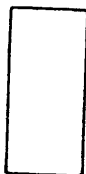
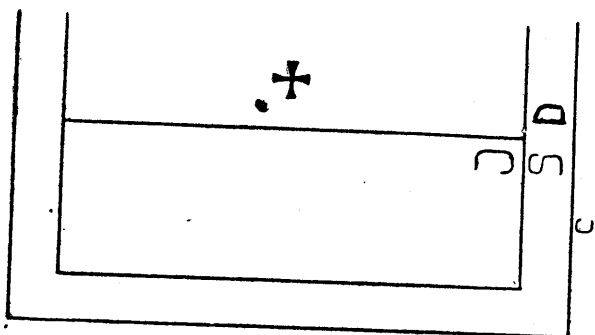

11. Đakon traži blagoslov za čitanje evanđelja

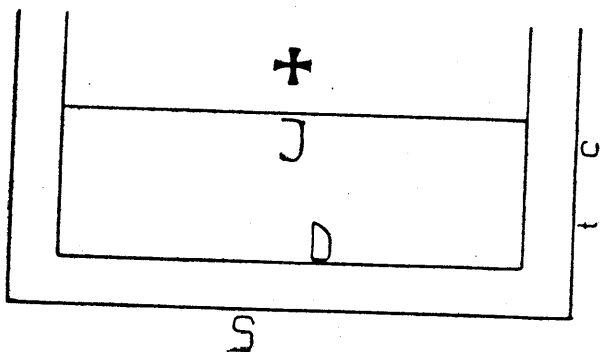

12. Pjevanje evanđelja

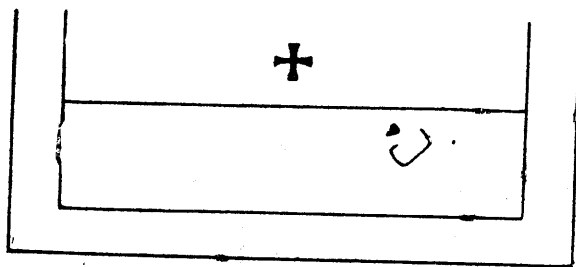

12
S
D
C

13. Prikazanje da stavljanja tamjana

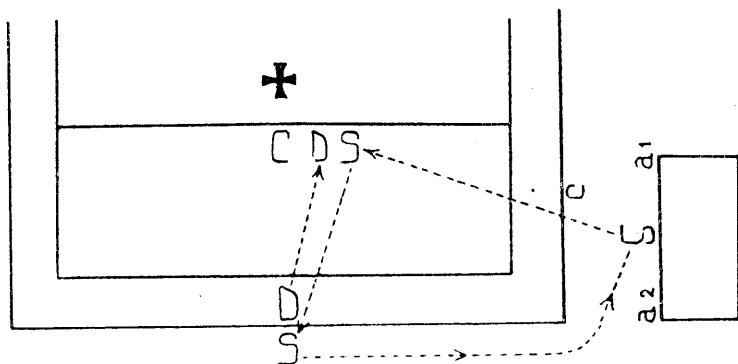

14. Kadenje žrtvenih darova.

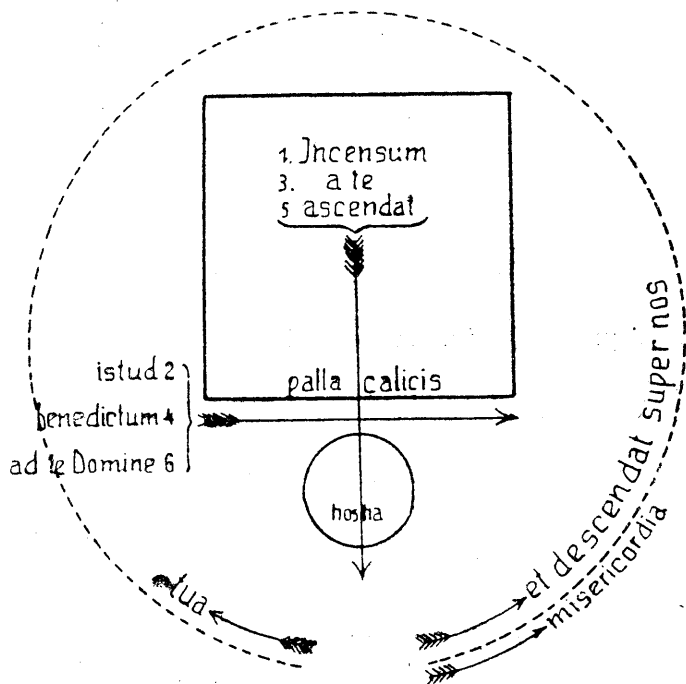

15. Secreta i praefacio

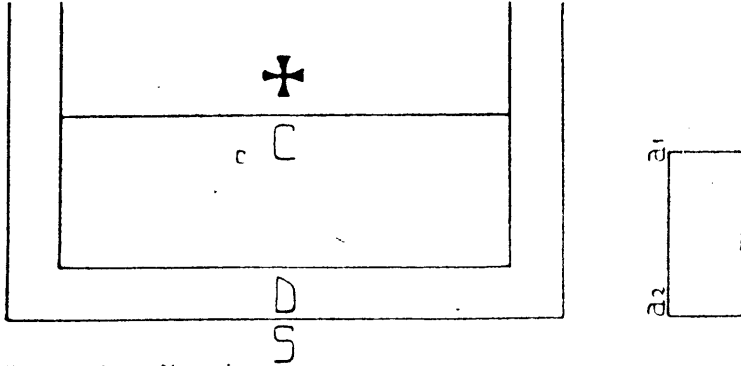

16. Kanon i podizanje

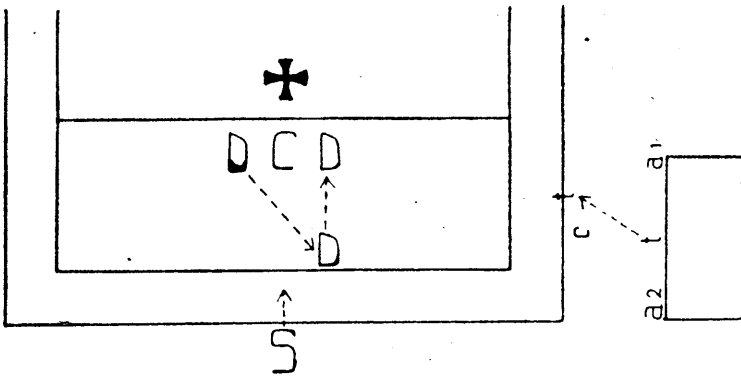

17. Poslije pretvorbe i „per quem haec omnia“

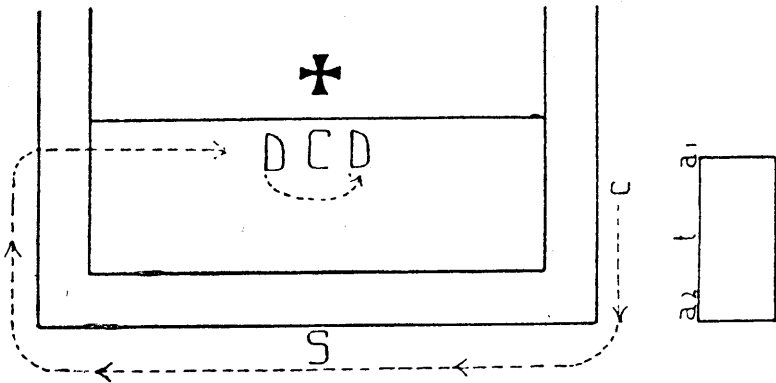

18. Pater noster i Et dimitte nobis

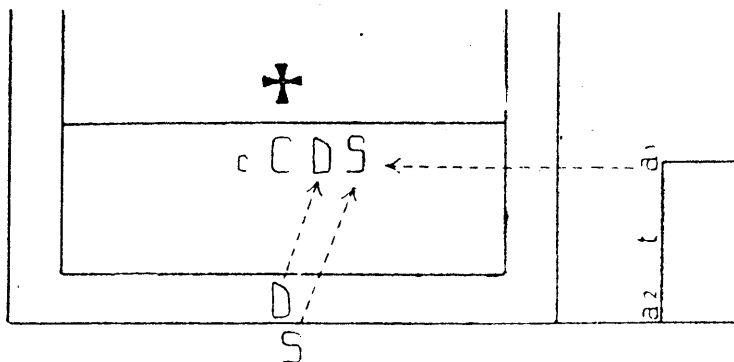

19. Celebrant daje „Pax“ dakonu

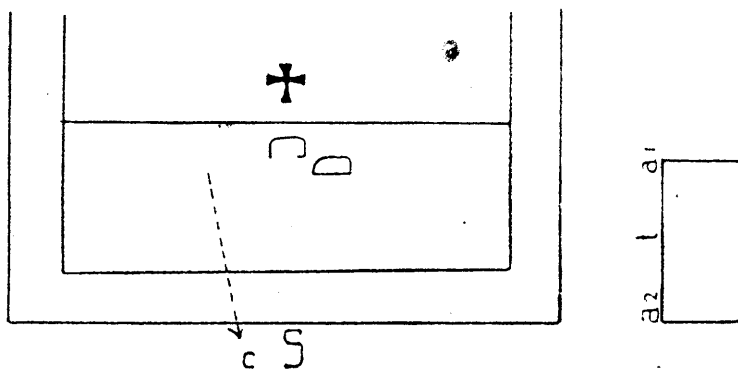

20. Đakon daje Pax subdakonu

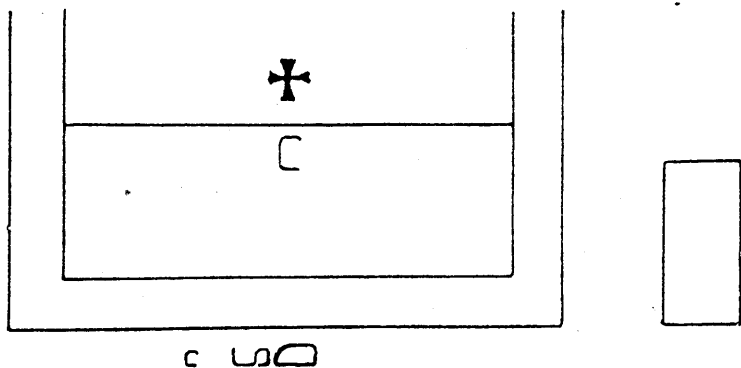

21. Pričest

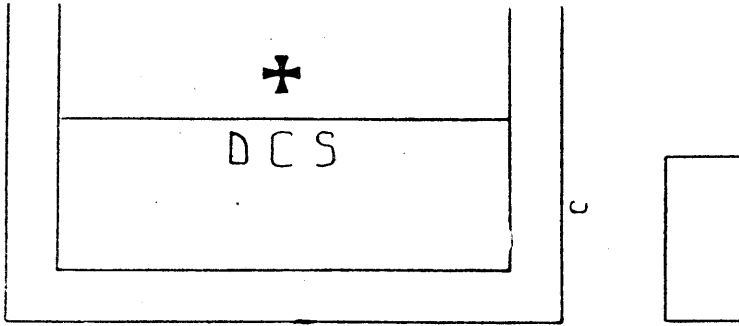

22. Purifikacija i oblucija

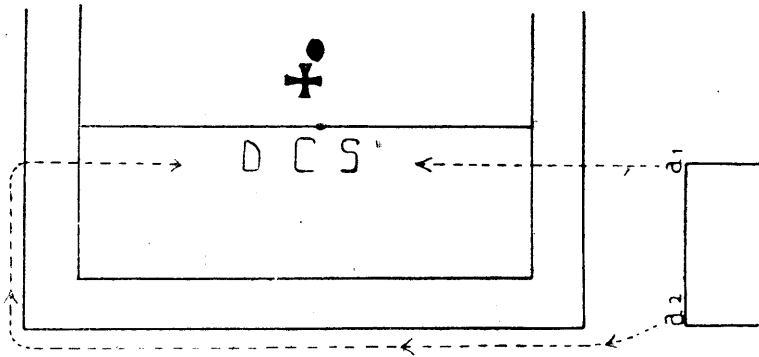

23. Communio

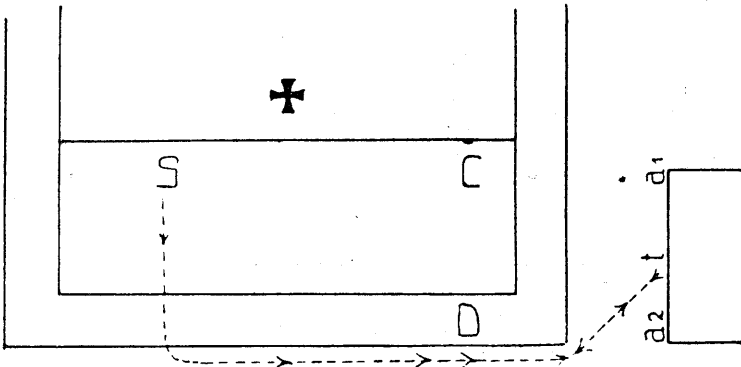

24. Ite missa est

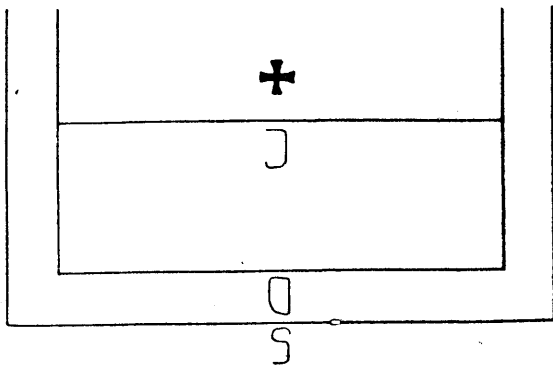

25. Blagoslov

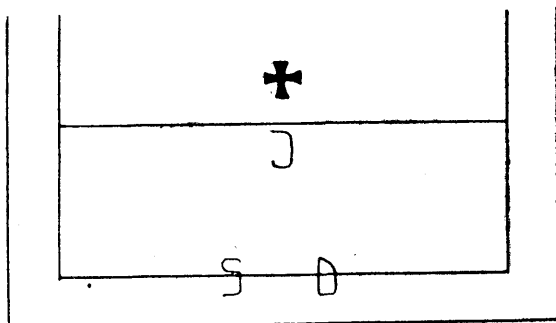

26. Reverencija oltara poslije-
mise

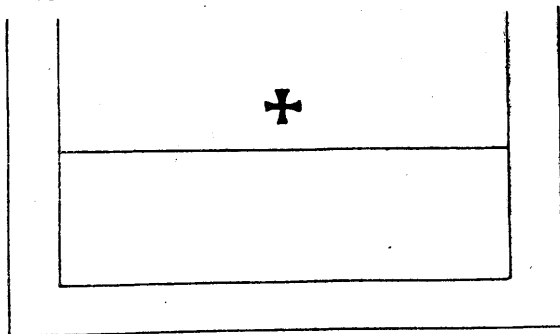

S_c C D
a₂ t a₁

Absolutio ad tumbam

a) s asistencijom

1. Kada je nazočno mrtvo tijelo
svećenika

k = knjiga
v = voda

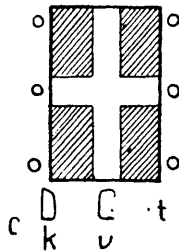
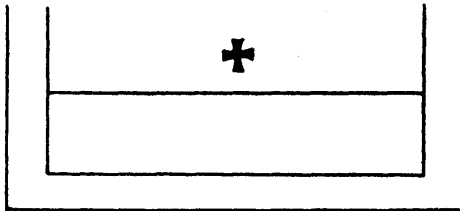

2. U svim drugim slučajevima

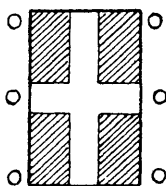
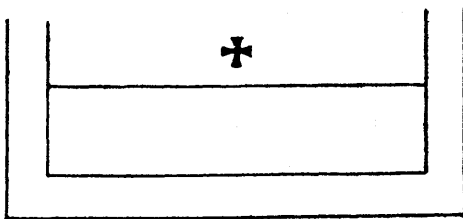

a2 S a1

b) bez asistencije

1. Kada je nazočno mrtvo tijelo
svećenika

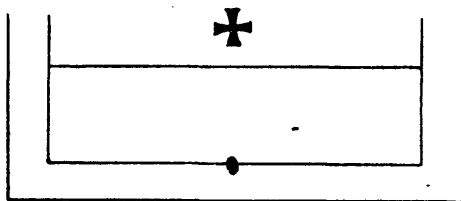

† (križ)

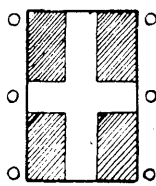

u [t

2. U svim drugim slučajevima

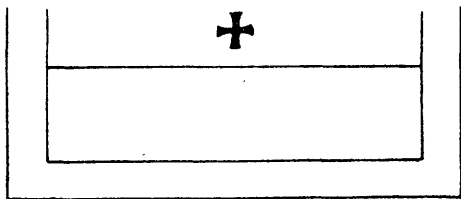

] n

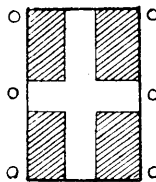

† (križ)

Veliki Petak

Ecce lignum crucis

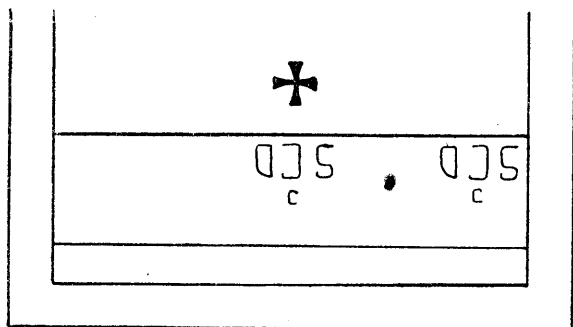

Velika Subota

1. Poslije blagoslova vatre dolazak pred oltar

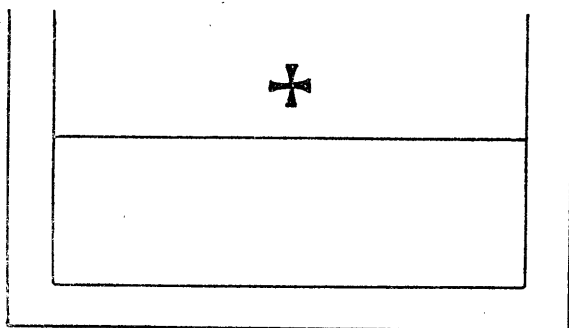

S s križem
 a₁ drži arundo
 a₂ drži zrna
 tamjana

t S C D_{a₁ a₂}
 c

2. Na „Exsultet“

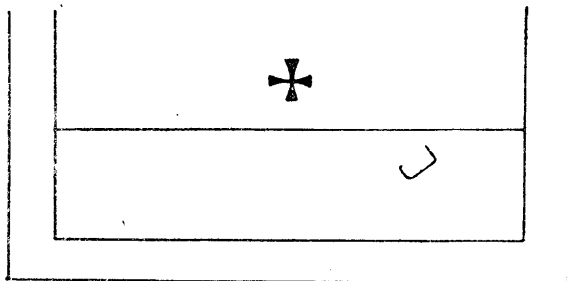

□ QJS_c
 a₂ a₁ t